



M-6066-SGT (Black)/M-6066-SGTP (Polished) SVT Mustang Supercharger Upgrade Kit INSTALLATION INSTRUCTIONS

NO PART OF THIS DOCUMENT MAY BE REPRODUCED WITHOUT PRIOR AGREEMENT AND WRITTEN PERMISSION OF FORD RACING PERFORMANCE PARTS.

Please contact the Techline for the most current instruction information (800) FORD788.

!!! PLEASE READ THE FOLLOWING INSTRUCTIONS CAREFULLY PRIOR TO INSTALLATION !!!



OVERVIEW:

This kit is designed for use on 2007-09 Ford SVT Mustangs.

NOTES:

- **BEFORE INSTALLING** the SVT Mustang Supercharger Upgrade Kit, please register this product by following the steps listed on the yellow voucher card included with the kit. **PRODUCT REGISTRATION IS REQUIRED** to receive the ProCal flash tool used to recalibrate the vehicle PCM. Operating the engine without the PCM recalibration will result in engine damage or failure and will **VOID THE WARRANTY**.
- Please read the installation instructions carefully and verify that all items are present. If you are missing hardware or have any questions, please contact the Ford Racing Techline at 1(800) FORD788.
- Premium fuel (91 octane or higher) is required to prevent "spark knock" or detonation under certain operating conditions. The use of fuel additives (i.e., octane boosters) is not recommended. There is a possibility that these chemicals can damage your engine and cause drivability issues with your vehicle.

WARNING: 2007 SVT Mustangs must use upgraded damper M-6312-SVT to maintain warranty coverage

Techline (800) FORD788

Factory Ford shop manuals are available from Helm Publications, 1-800-782-4356

IS-1850-0146



M-6066-SGT (Black)/M-6066-SGTP (Polished) SVT Mustang Supercharger Upgrade Kit INSTALLATION INSTRUCTIONS

NO PART OF THIS DOCUMENT MAY BE REPRODUCED WITHOUT PRIOR AGREEMENT AND WRITTEN PERMISSION OF FORD RACING PERFORMANCE PARTS.

KIT INCLUDES:



1



2



3



4



5



6



7

<u>Item #</u>	<u>Qty</u>	<u>Part Number</u>	<u>Description</u>
1	1	R07060101	Clean Air Tube
2	1	R07060106	Airbox Assembly
3	1	R07060131	High-Flow Conical Air Filter w/Worm Clamp
4	1	R07060104	Clean Air Tube Support Bracket
5	3	N605771	Bolt – Bracket to Tube and Airbox (M6 x 13)
6	1	N808920	Bolt – Airbox to ABS Bracket (M8 x 33)
7	1	R07040053	E.O. Label (D-418-10)

Techline (800) FORD788

Factory Ford shop manuals are available from Helm Publications, 1-800-782-4356



M-6066-SGT (Black)/M-6066-SGTP (Polished) SVT Mustang Supercharger Upgrade Kit INSTALLATION INSTRUCTIONS

NO PART OF THIS DOCUMENT MAY BE REPRODUCED WITHOUT PRIOR AGREEMENT AND WRITTEN PERMISSION OF FORD RACING PERFORMANCE PARTS.



8



9

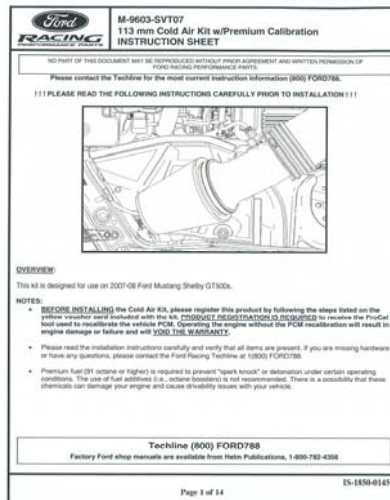

10



11

Item #	Qty	Part Number	Description
8	1	R07050050	TVS2300 Supercharger (Black Finish)
9	1	R07140004	Registration/Warranty Voucher
10	1	IS-1850-0146	Installation Instructions
11	0**	NPN	ProCal Flash Tool (ProCal 1 pictured)

The ProCal flash tool is **NOT included in the kit. Once you **register** the product and **request** the Pro-Cal tool, one will be shipped to you.

Techline (800) FORD788

Factory Ford shop manuals are available from Helm Publications, 1-800-782-4356



M-6066-SGT (Black)/M-6066-SGTP (Polished) SVT Mustang Supercharger Upgrade Kit INSTALLATION INSTRUCTIONS

NO PART OF THIS DOCUMENT MAY BE REPRODUCED WITHOUT PRIOR AGREEMENT AND WRITTEN PERMISSION OF FORD RACING PERFORMANCE PARTS.

EQUIPMENT AND SUPPLIES REQUIRED:

- 1/4" and 3/8" drive ratchets with extensions
- Metric and standard socket sets (short and deep recommended)
- 3/8" drive ratchet or breaker bar
- Metric and standard wrench sets
- Torque wrenches
- Short Phillips-head screwdriver
- Hex key set
- T-20 Torx Bit screwdriver or socket
- Thread sealing compound
- Medium-strength thread locker – Loctite 242 (blue) or equivalent
- Ford Service Manual

GLOSSARY OF TERMS:

ACT	Air Charger Temperature Sensor
ETC	Electronic Throttle Control
IPTS	Injection Pressure and Temperature Sensor
MAFS	Mass Air Flow Sensor
PCM	Powertrain Control Module (a.k.a. ECM, ECU, PCU, EEC)
PCV	Positive Crankcase Ventilation
TPS	Throttle Position Sensor
VMV	Vapor Management Valve (located on driver side strut tower brace)

INFORMATION ABOUT THE SUPERCHARGER BYPASS OPERATION:

There is a great deal of misinformation about the function of supercharger bypass systems. The supercharger is a positive-displacement pump; that is, so long as it is rotating, it is always pumping air. During low demand or high vacuum operation (i.e., idle, deceleration and light throttle cruise), the pumping action is undesirable as it creates unwanted heat and noise. The bypass circuit, when open, prevents any pressure buildup across the supercharger and allows air to circulate through the rotors, allowing the supercharger to "idle" freely during these conditions. This results in reduced noise, and by reducing heat buildup in the intake, significantly improves street and strip performance. As throttle demand increases, the bypass circuit is closed, resulting in full performance from the supercharger. The bypass circuit is never used to limit or control boost during full-throttle operation and defeating or altering the bypass function will not result in improved performance in any condition, and will result in poor drivability.

Techline (800) FORD788

Factory Ford shop manuals are available from Helm Publications, 1-800-782-4356



M-6066-SGT (Black)/M-6066-SGTP (Polished) SVT Mustang Supercharger Upgrade Kit INSTALLATION INSTRUCTIONS

NO PART OF THIS DOCUMENT MAY BE REPRODUCED WITHOUT PRIOR AGREEMENT AND WRITTEN PERMISSION OF FORD RACING PERFORMANCE PARTS.

SAFETY PRECAUTIONS:

!!! STOP! CAREFULLY READ THE IMPORTANT SAFETY PRECAUTIONS AND WARNINGS BEFORE PROCEEDING WITH THE INSTALLATION !!!

Appropriate disassembly and assembly methods and procedures are essential to ensure the personal safety of the individual performing the kit installation. Improper installation due to the failure to correctly follow these instructions could cause personal injury or death. Read each step of the installation instructions carefully before starting the installation.

- Always wear safety glasses for eye protection.
- Place ignition switch in the OFF position.
- Always apply the parking brake when working on the vehicle.
- Block the front and rear tire surfaces to prevent unexpected vehicle movement.
- Operate the engine only in well-ventilated areas to avoid exposure to carbon monoxide.
- Do not smoke or use flammable items near or around the fuel system.
- Use chemicals and cleaners only in well-ventilated areas.
- Batteries can produce explosive hydrogen gas, which can cause personal injury. Therefore, do not allow flames, sparks or flammable sources to come near the battery.
- Keep hands and any other objects away from the radiator fan blades.
- Keep yourself and your clothing away from moving parts when the engine is running.
- Do not wear loose clothing or jewelry which can be caught in rotating or moving parts.

DISASSEMBLY INSTRUCTIONS:

The following section will guide you through the disassembly of the stock components. Special care should be taken to label fasteners and parts that are taken off during this procedure since many will be reused.

STEP 1: Cover both fenders with fender covers to protect the vehicle finish.

STEP 2: Release the fuel system pressure (**NOTE:** The following procedure is taken directly from the Ford Service Manual, section 310-00.)

!!! WARNING: FUEL IN THE FUEL SYSTEM REMAINS UNDER HIGH PRESSURE EVEN WHEN THE ENGINE IS NOT RUNNING. BEFORE WORKING ON OR DISCONNECTING ANY OF THE FUEL LINES OR FUEL SYSTEM COMPONENTS, THE FUEL SYSTEM PRESSURE MUST BE RELIEVED. FAILURE TO DO SO CAN RESULT IN PERSONAL INJURY !!!

!!! WARNING: DO NOT SMOKE OR CARRY LIGHTED TOBACCO OR OPEN FLAME OF ANY TYPE WHEN WORKING ON OR NEAR ANY FUEL-RELATED COMPONENTS. HIGHLY FLAMMABLE MIXTURES ARE ALWAYS PRESENT AND CAN BE IGNITED, RESULTING IN PERSONAL INJURY !!!

Techline (800) FORD788

Factory Ford shop manuals are available from Helm Publications, 1-800-782-4356

IS-1850-0146



M-6066-SGT (Black)/M-6066-SGTP (Polished) SVT Mustang Supercharger Upgrade Kit INSTALLATION INSTRUCTIONS

NO PART OF THIS DOCUMENT MAY BE REPRODUCED WITHOUT PRIOR AGREEMENT AND WRITTEN PERMISSION OF FORD RACING PERFORMANCE PARTS.

- a. Remove the fuel pump module fuse.

NOTE: The fuel pump module fuse is located in the bussed electrical center, location F41 (See Fig. 1).

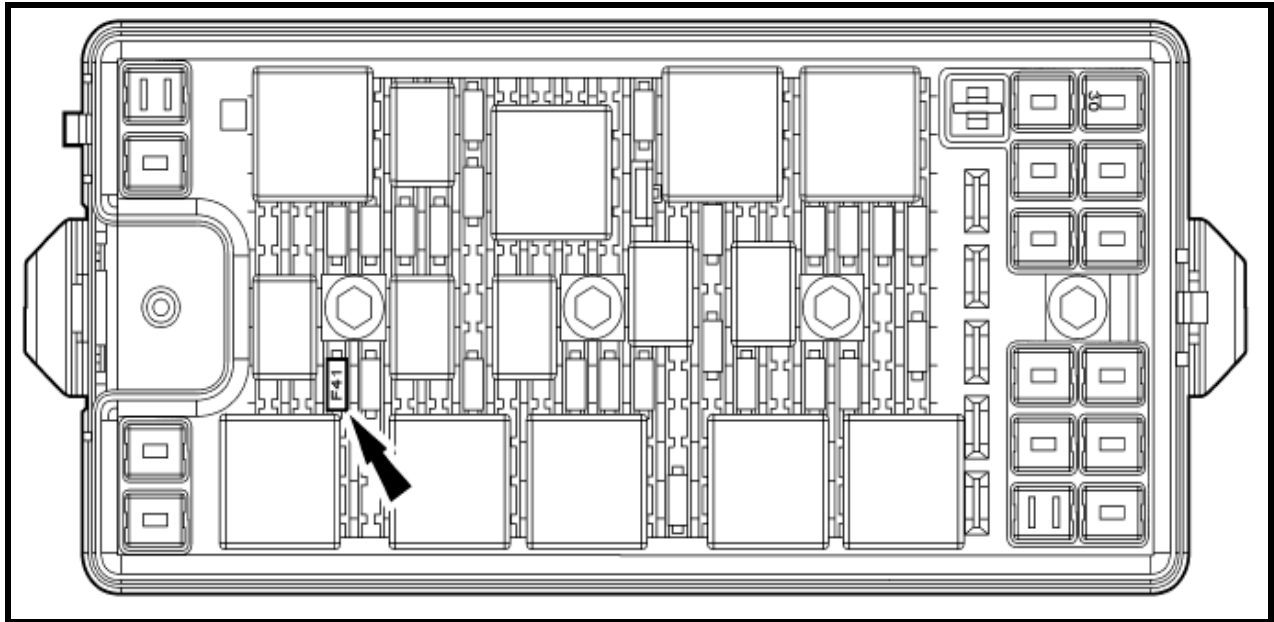

Fig. 1

- b. Start the engine and allow it to idle until it stalls.
- c. After the engine stalls, crank the engine for approximately five seconds to make sure the fuel injector supply manifold pressure has been released.
- d. Turn the ignition switch to the OFF position.

STEP 3: Disconnect the negative (-) and positive (+) connections to the battery. Cover the positive (+) battery terminal to prevent any contact.

Techline (800) FORD788

Factory Ford shop manuals are available from Helm Publications, 1-800-782-4356



M-6066-SGT (Black)/M-6066-SGTP (Polished) SVT Mustang Supercharger Upgrade Kit INSTALLATION INSTRUCTIONS

NO PART OF THIS DOCUMENT MAY BE REPRODUCED WITHOUT PRIOR AGREEMENT AND WRITTEN PERMISSION OF FORD RACING PERFORMANCE PARTS.

STEP 4: Remove the factory strut tower brace (See Fig. 2).

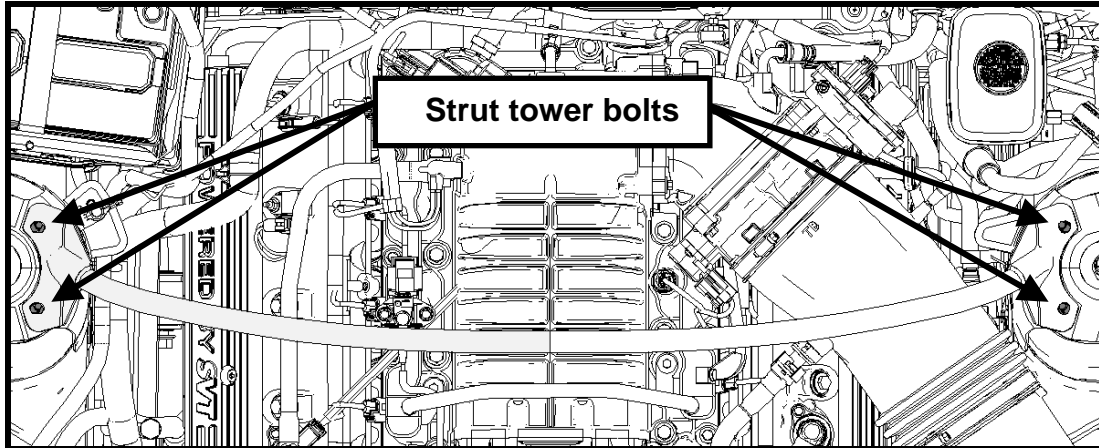

Fig. 2

STEP 5: Carefully label each port before removing the vacuum harness from the vehicle (i.e., supercharger housing, ESM and supercharger bypass actuator) (See Fig. 3).

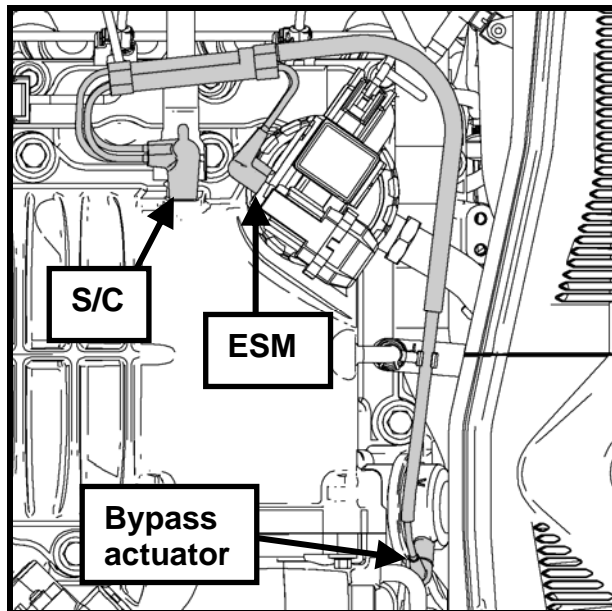

Fig. 3

NOTE: A separate vacuum line connects the bypass actuator to the clean air tube. This will be disconnected from the supercharger later.

Techline (800) FORD788

Factory Ford shop manuals are available from Helm Publications, 1-800-782-4356

NO PART OF THIS DOCUMENT MAY BE REPRODUCED WITHOUT PRIOR AGREEMENT AND WRITTEN PERMISSION OF FORD RACING PERFORMANCE PARTS.

STEP 6: Disconnect the electrical connector from the MAF sensor. Disconnect the vacuum harness and PCV hose from the clean air tube. Remove the clean air tube from the airbox and throttle body (See Fig. 4).

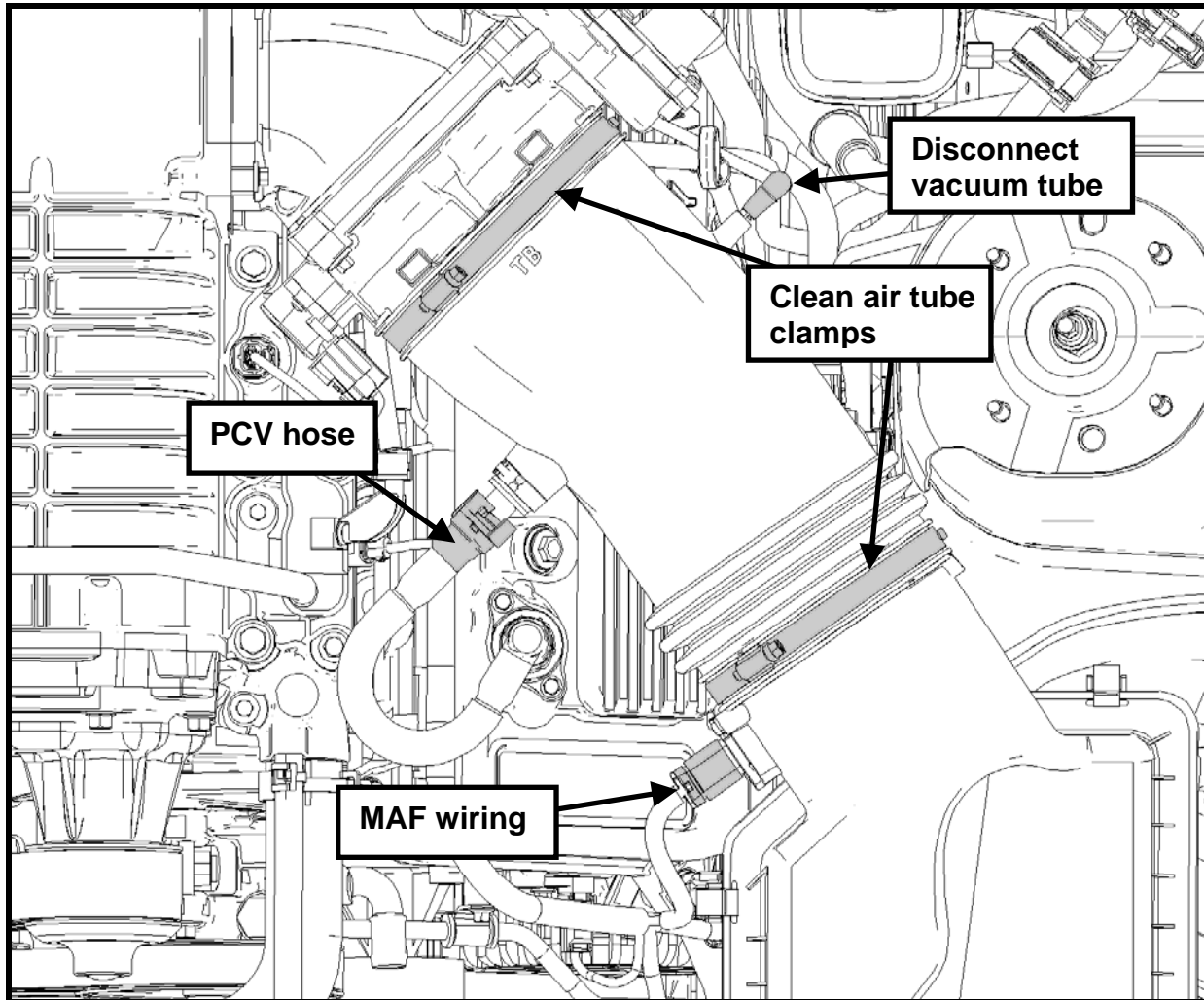

Fig. 4

Techline (800) FORD788

Factory Ford shop manuals are available from Helm Publications, 1-800-782-4356

NO PART OF THIS DOCUMENT MAY BE REPRODUCED WITHOUT PRIOR AGREEMENT AND WRITTEN PERMISSION OF FORD RACING PERFORMANCE PARTS.

STEP 7: Remove the airbox retainer bolt and assembly from the vehicle (See Fig. 5).

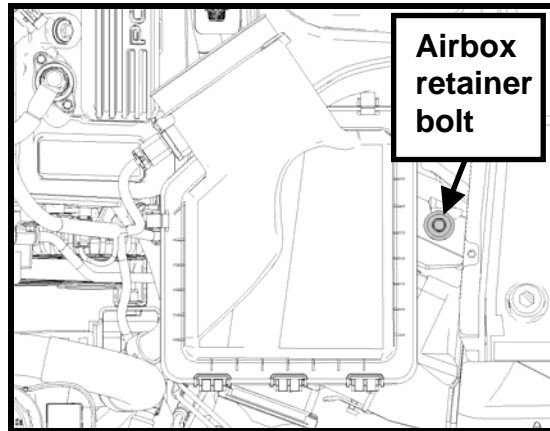

Fig. 5

STEP 8: Remove the three grommets, MAF and MAF bolts from the factory airbox (See Fig. 6). These will be reused later.

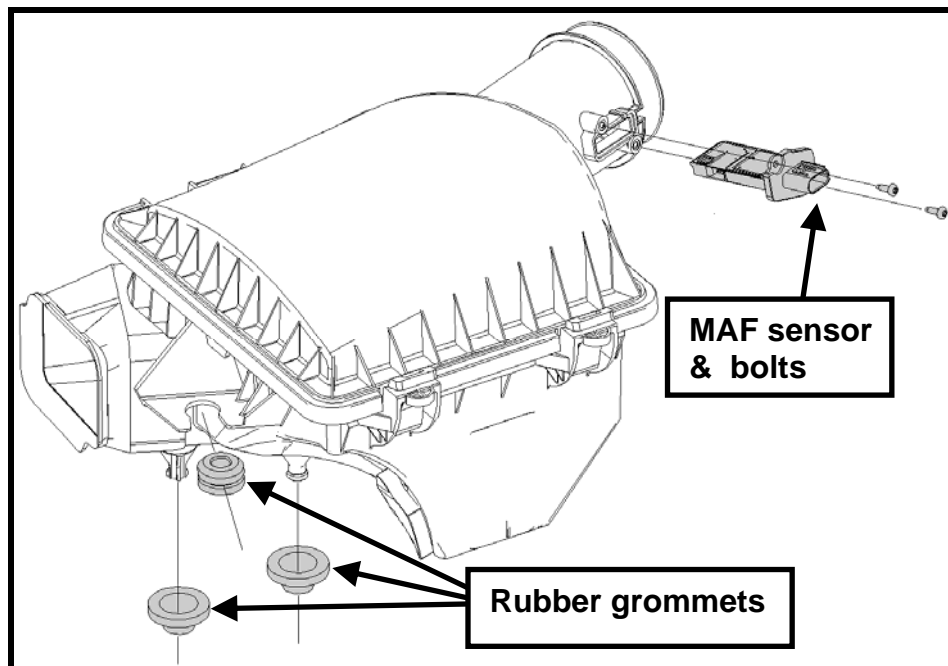

Fig. 6

Techline (800) FORD788

Factory Ford shop manuals are available from Helm Publications, 1-800-782-4356

NO PART OF THIS DOCUMENT MAY BE REPRODUCED WITHOUT PRIOR AGREEMENT AND WRITTEN PERMISSION OF FORD RACING PERFORMANCE PARTS.

STEP 9: Disconnect the throttle body wiring in two places (ETC and TPS connections). Disconnect the brake booster and VMV hoses from the throttle body spacer (See Fig. 7). Remove the throttle body spacer (including throttle body) from the supercharger (See Fig. 8).

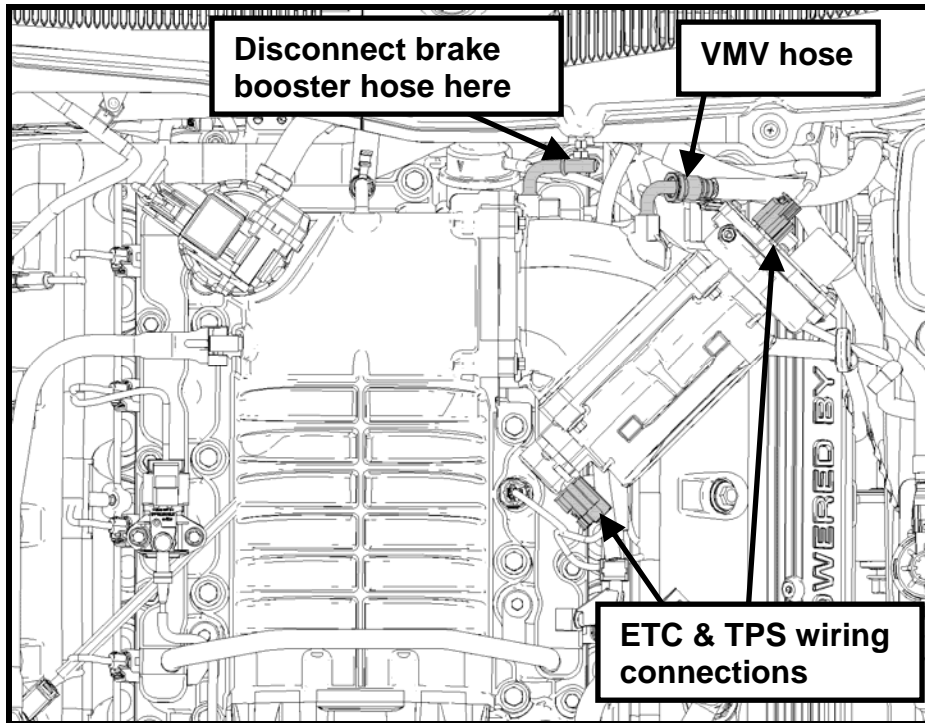

Fig. 7

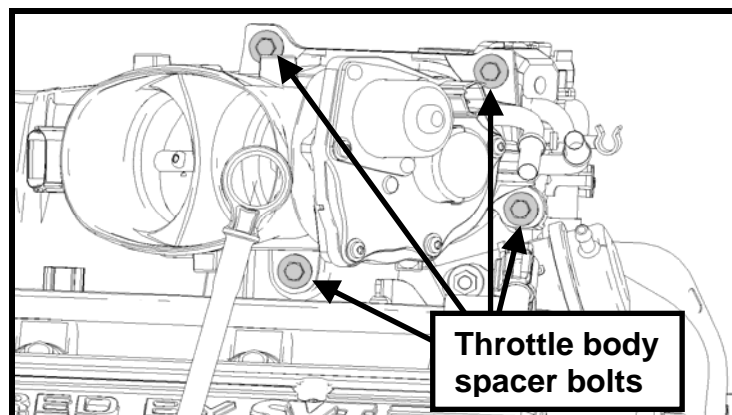

Fig. 8

Techline (800) FORD788

Factory Ford shop manuals are available from Helm Publications, 1-800-782-4356

NO PART OF THIS DOCUMENT MAY BE REPRODUCED WITHOUT PRIOR AGREEMENT AND WRITTEN PERMISSION OF FORD RACING PERFORMANCE PARTS.

STEP 10: Remove the ESM (EGR System Module) electrical connector. Remove the EGR tube nut from the ESM (See Fig. 9). Remove the ESM bolts and assembly from the supercharger (See Fig. 10).

NOTE: The ESM gasket will be reused. It is important that it does not become damaged or lost.

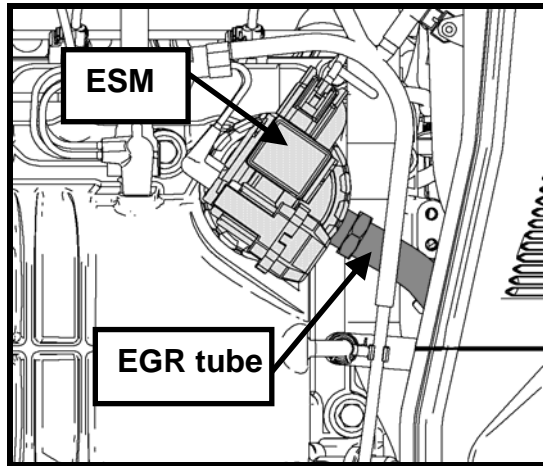

Fig. 9

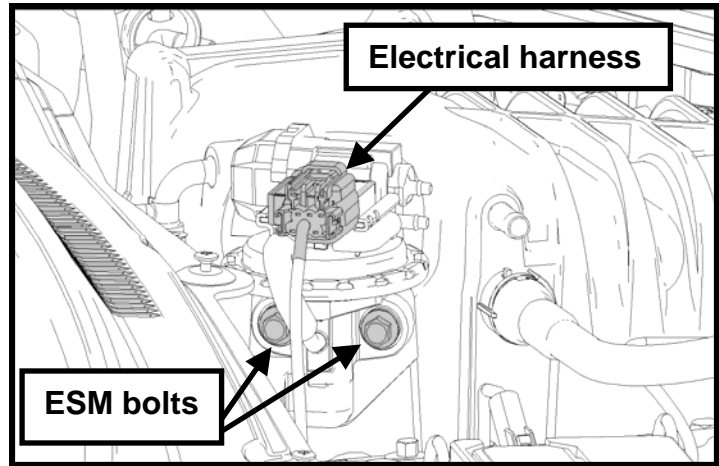

Fig. 10

STEP 11: Disconnect the PCV and PCV bubbler hoses from the supercharger (See Fig. 11).

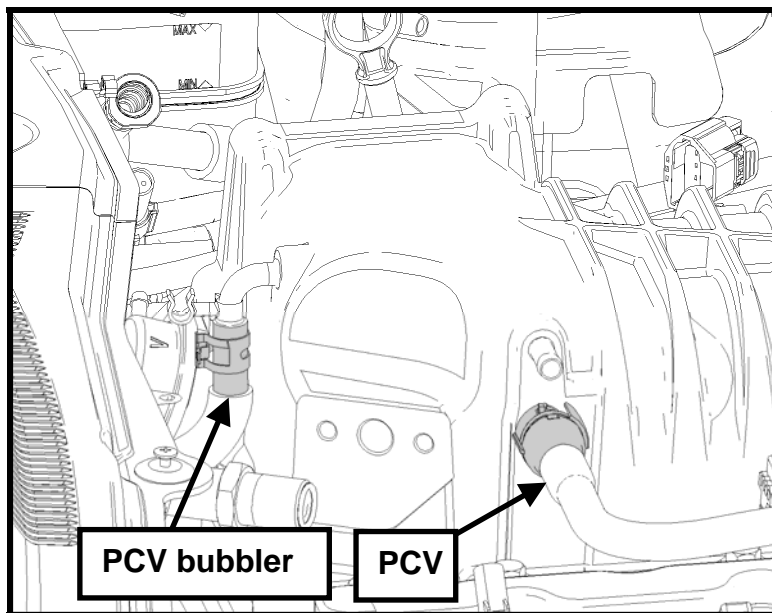

Fig. 11

Techline (800) FORD788

Factory Ford shop manuals are available from Helm Publications, 1-800-782-4356

NO PART OF THIS DOCUMENT MAY BE REPRODUCED WITHOUT PRIOR AGREEMENT AND WRITTEN PERMISSION OF FORD RACING PERFORMANCE PARTS.

STEP 12: Remove the two degas bottle fasteners. Make sure the cap is tightly secured. Rotate the degas bottle out of the way to gain additional access to the FEAD belt tensioner (See Fig. 12).

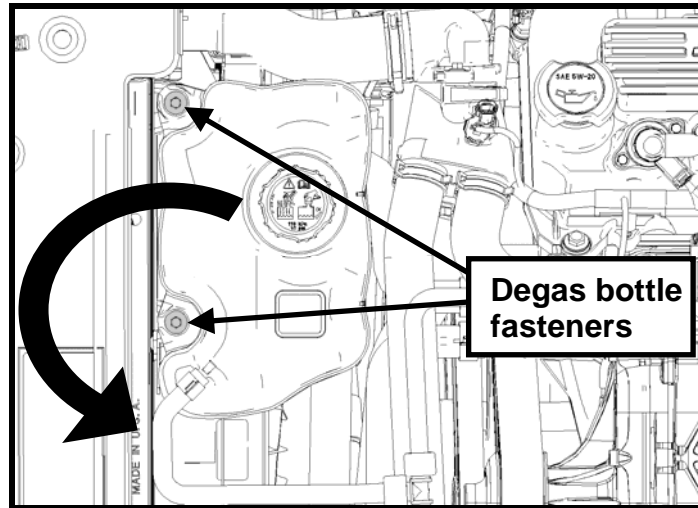

Fig. 12

STEP 13: Use a 3/8" breaker bar to release the first sheave tensioner and remove the FEAD belt from the supercharger (S/C) pulley (See Fig. 13).

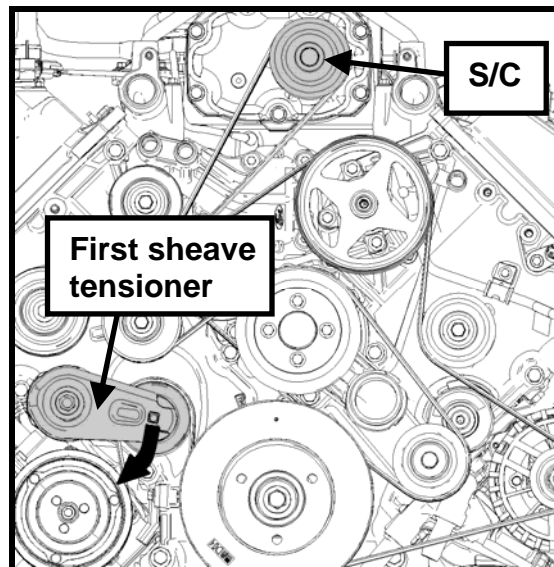

Fig. 13

Techline (800) FORD788

Factory Ford shop manuals are available from Helm Publications, 1-800-782-4356

NO PART OF THIS DOCUMENT MAY BE REPRODUCED WITHOUT PRIOR AGREEMENT AND WRITTEN PERMISSION OF FORD RACING PERFORMANCE PARTS.

STEP 14: Disconnect the wiring harness and vacuum tube from the fuel rail pressure sensor (IPTS). Disconnect the wiring harness from the ACT sensor (See Fig. 14).

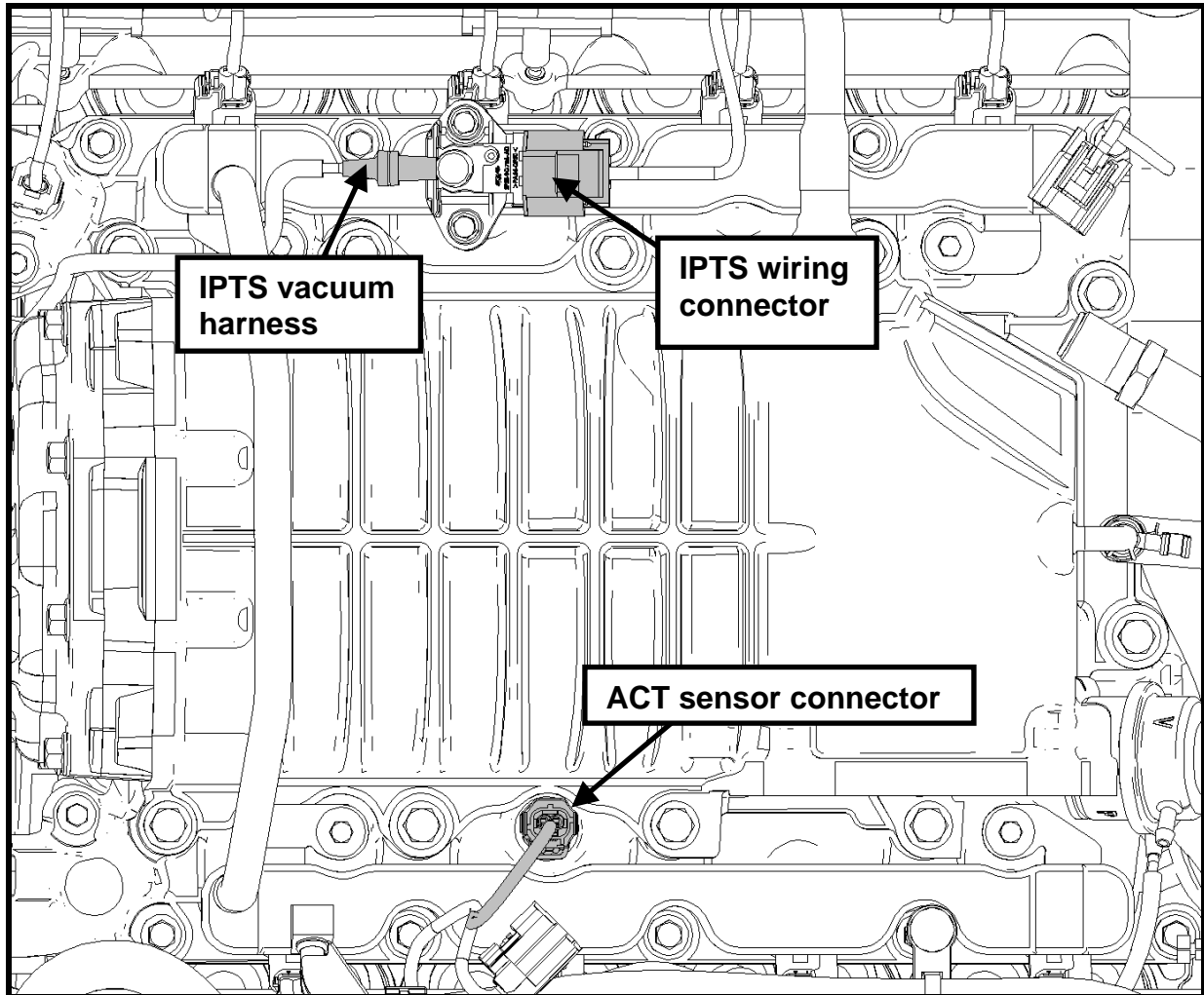

Fig. 14

STEP 15: Disconnect all eight fuel injector wiring connectors (See Fig. 15).

Techline (800) FORD788

Factory Ford shop manuals are available from Helm Publications, 1-800-782-4356



M-6066-SGT (Black)/M-6066-SGTP (Polished) SVT Mustang Supercharger Upgrade Kit INSTALLATION INSTRUCTIONS

NO PART OF THIS DOCUMENT MAY BE REPRODUCED WITHOUT PRIOR AGREEMENT AND WRITTEN PERMISSION OF FORD RACING PERFORMANCE PARTS.

STEP 16: Remove the fuel rail mounting bolts (See Fig. 15). Pull up on the fuel rail and all eight injectors to gain access to the supercharger. Rotate the fuel rail around the fuel rail supply line and set aside on the driver side strut tower.

!!! WARNING: DO NOT SMOKE OR CARRY LIGHTED TOBACCO OR OPEN FLAME OF ANY TYPE WHEN WORKING ON OR NEAR ANY FUEL-RELATED COMPONENTS. HIGHLY FLAMMABLE MIXTURES ARE ALWAYS PRESENT AND CAN BE IGNITED, RESULTING IN PERSONAL INJURY !!!

!!! WARNING: FUEL IN THE FUEL SYSTEM REMAINS UNDER HIGH PRESSURE EVEN WHEN THE ENGINE IS NOT RUNNING. BEFORE WORKING ON OR DISCONNECTING ANY OF THE FUEL LINES OR FUEL SYSTEM COMPONENTS, THE FUEL SYSTEM PRESSURE MUST BE RELIEVED. FAILURE TO DO SO CAN RESULT IN PERSONAL INJURY !!!

NOTE: Be careful not to get any contaminants in the injectors or into the boss on the intake manifold. Be careful not to damage the O-rings on the injectors.

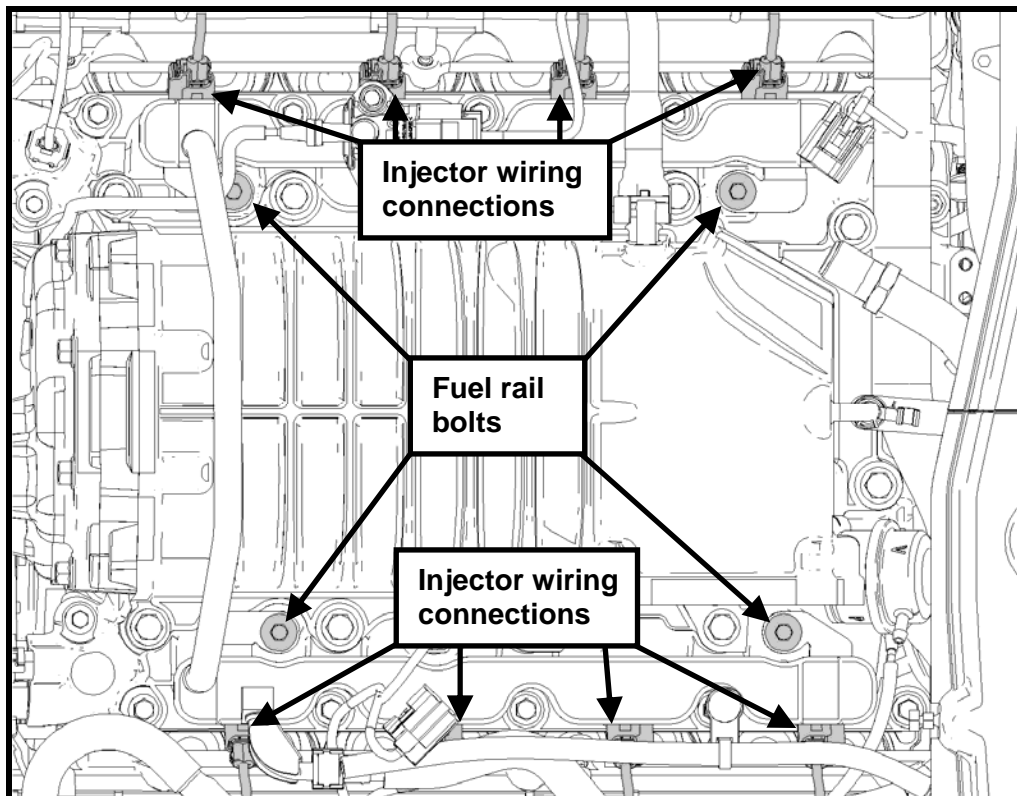

Fig. 15

Techline (800) FORD788

Factory Ford shop manuals are available from Helm Publications, 1-800-782-4356



M-6066-SGT (Black)/M-6066-SGTP (Polished) SVT Mustang Supercharger Upgrade Kit INSTALLATION INSTRUCTIONS

NO PART OF THIS DOCUMENT MAY BE REPRODUCED WITHOUT PRIOR AGREEMENT AND WRITTEN PERMISSION OF FORD RACING PERFORMANCE PARTS.

STEP 17: Remove the supercharger mounting fasteners and carefully remove the supercharger from the vehicle. If the dowel pins did not remain in the intake manifold, remove them from the supercharger and re-install into the intake. Transfer the vacuum line (attached to the supercharger bypass valve) to the new supercharger. **NOTE:** Attempt to maintain the stock orientation and connect to the lower port.

INSTALLATION INSTRUCTIONS:

The following section will guide you through the installation of this kit. If you need to stop during any part of the installation, make sure you cover any open ports in the cylinder heads or intake manifold to prevent foreign material from contaminating your engine.

STEP 1: Install the new supercharger to the intake manifold using the stock fasteners. Torque the fasteners to 5 Nm (44 lb in) using the inside-out pattern shown below (See Fig. 16). Repeat this procedure and torque each fastener to 25 Nm (221 lb in)

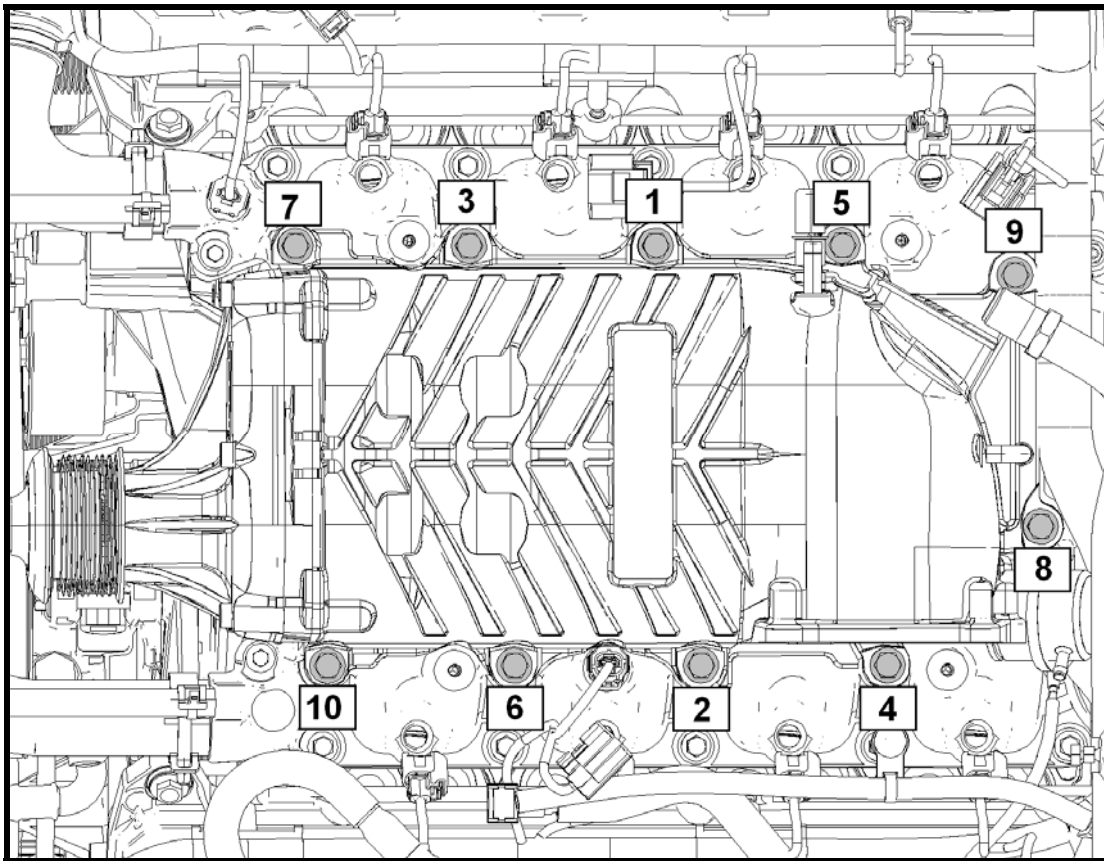

Fig. 16

Techline (800) FORD788

Factory Ford shop manuals are available from Helm Publications, 1-800-782-4356

NO PART OF THIS DOCUMENT MAY BE REPRODUCED WITHOUT PRIOR AGREEMENT AND WRITTEN PERMISSION OF FORD RACING PERFORMANCE PARTS.

STEP 2: Re-install the injectors and fuel rail onto the intake manifold (See Fig. 17). Torque fuel rail bolts to 10 Nm (88 lb in)

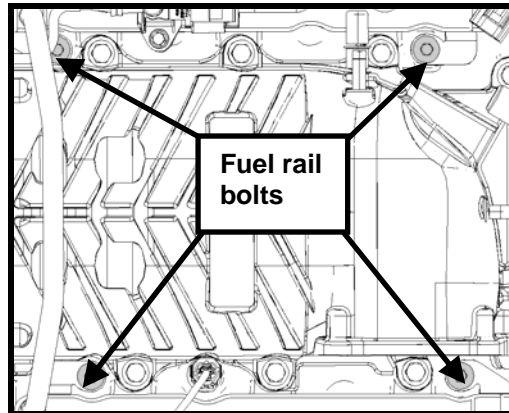

Fig. 17

STEP 3: Connect fuel injector wiring harnesses, fuel pressure regulator (IPTS) electrical harness, vacuum harness and ACT wiring connector (See Fig. 18).

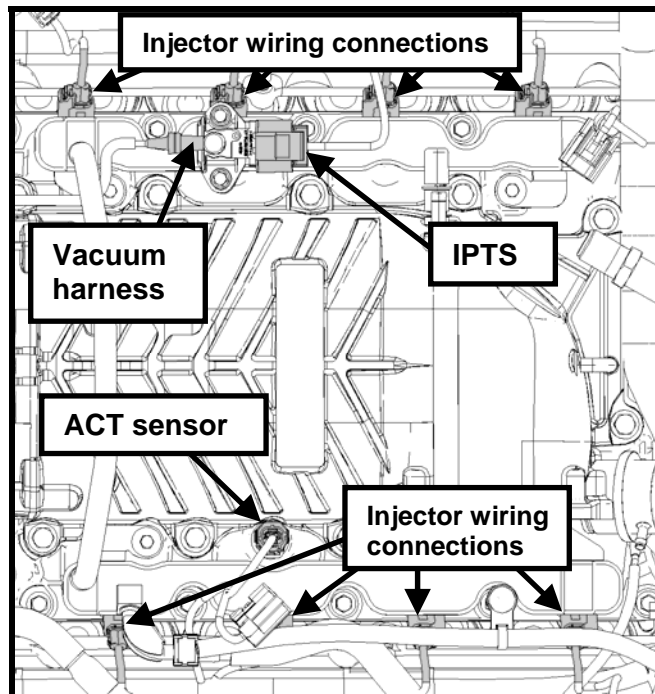

Fig. 18

Techline (800) FORD788

Factory Ford shop manuals are available from Helm Publications, 1-800-782-4356



M-6066-SGT (Black)/M-6066-SGTP (Polished) SVT Mustang Supercharger Upgrade Kit INSTALLATION INSTRUCTIONS

NO PART OF THIS DOCUMENT MAY BE REPRODUCED WITHOUT PRIOR AGREEMENT AND WRITTEN PERMISSION OF FORD RACING PERFORMANCE PARTS.

STEP 4:

Re-install the FEAD belt over the supercharger pulley by using a breaker bar to release the tensioner (See Fig. 19).

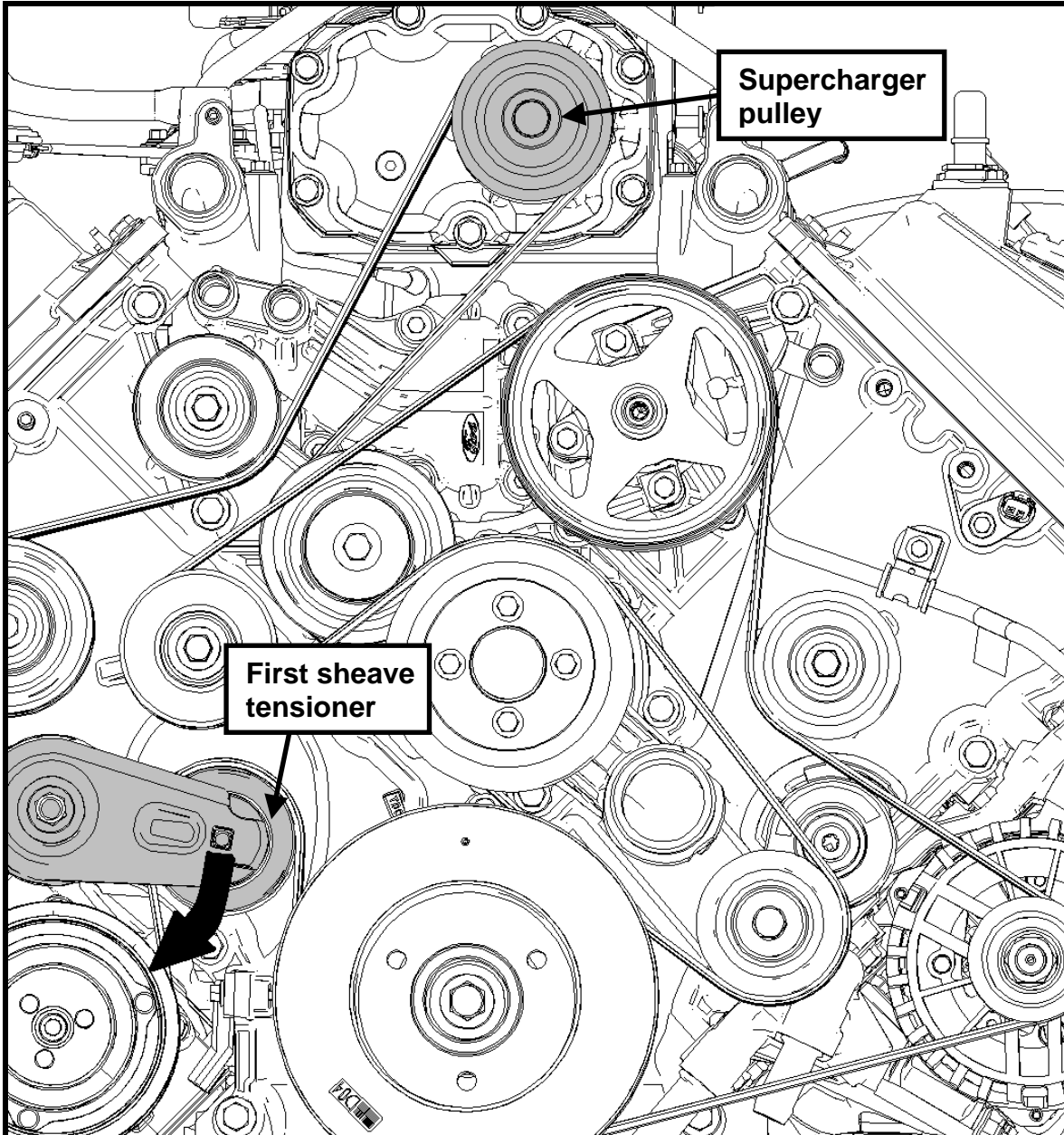

Fig. 19

Techline (800) FORD788

Factory Ford shop manuals are available from Helm Publications, 1-800-782-4356

NO PART OF THIS DOCUMENT MAY BE REPRODUCED WITHOUT PRIOR AGREEMENT AND WRITTEN PERMISSION OF FORD RACING PERFORMANCE PARTS.

STEP 5: Rotate the degas bottle back into place. Re-install the two fasteners used to secure the degas bottle in place and torque to 10 Nm (88 lb in) (See Fig. 20).

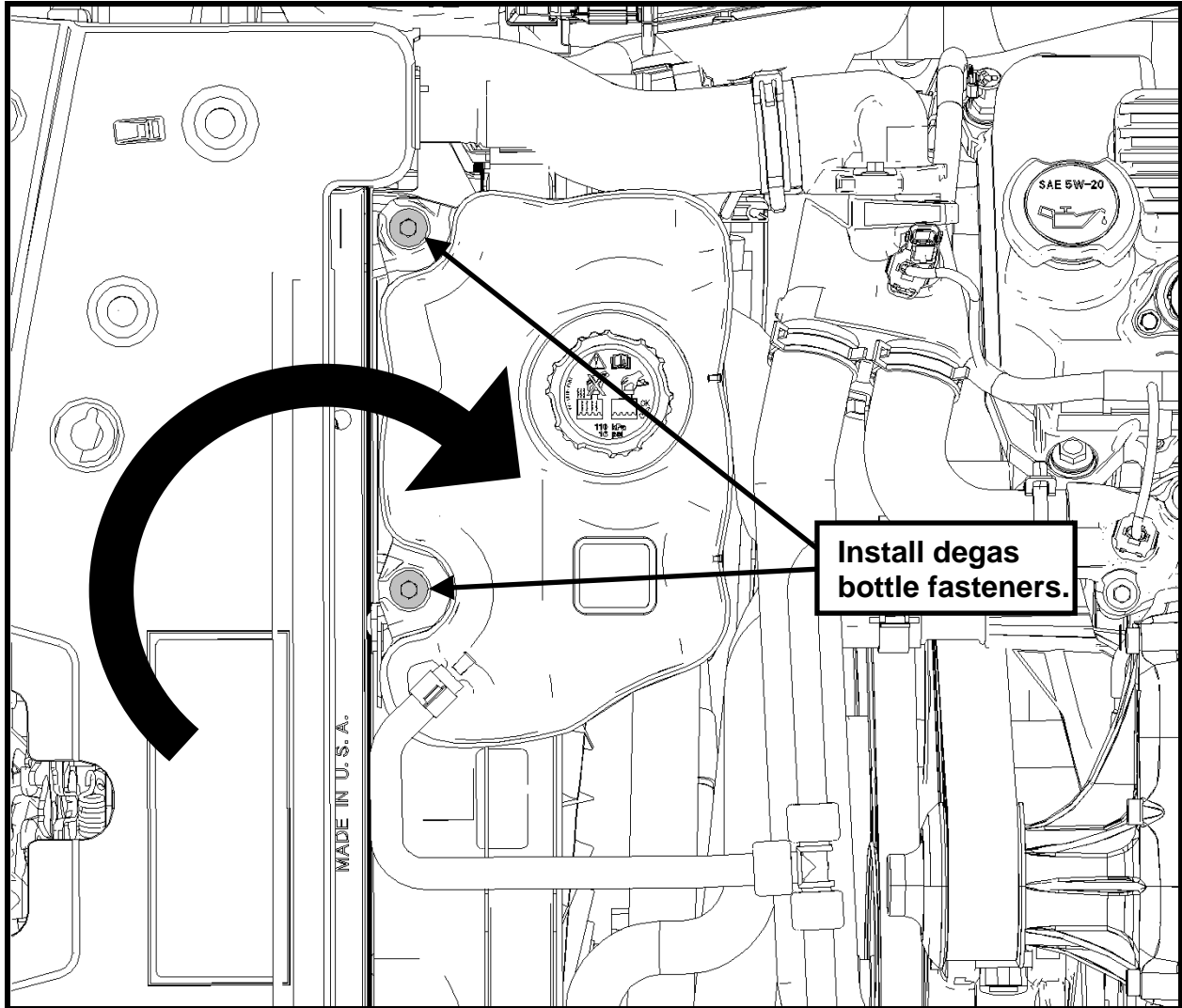

Fig. 20

Techline (800) FORD788

Factory Ford shop manuals are available from Helm Publications, 1-800-782-4356

NO PART OF THIS DOCUMENT MAY BE REPRODUCED WITHOUT PRIOR AGREEMENT AND WRITTEN PERMISSION OF FORD RACING PERFORMANCE PARTS.

STEP 6: Re-install the PCV and PCV bubbler lines to the supercharger housing (See Fig. 21).

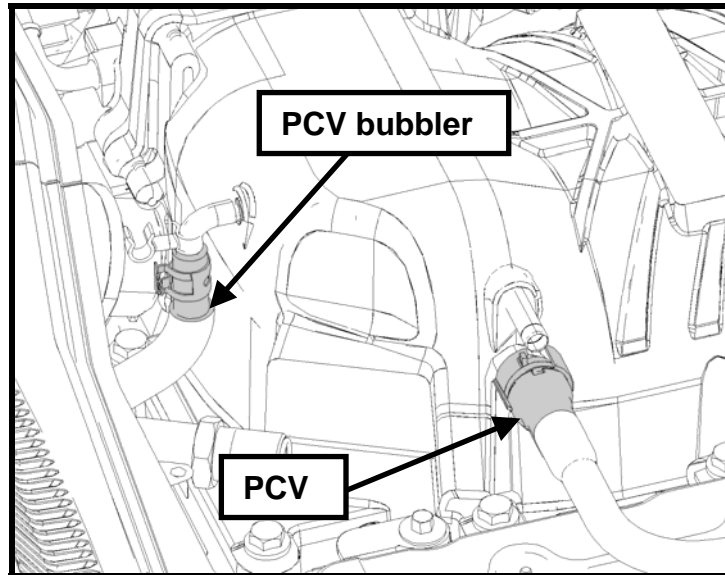

Fig. 21

STEP 7: Apply a thread sealing compound to the stock EGR bolts. Install the ESM and torque the bolts to 25 Nm (221 lb in) (See Fig. 22). Connect ESM electrical harness and the EGR tube (See Fig. 23). Torque the EGR tube to 35 Nm (309 lb in)

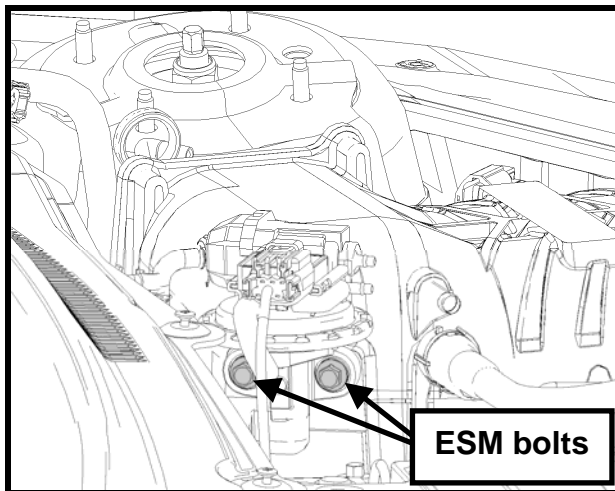

Fig. 22

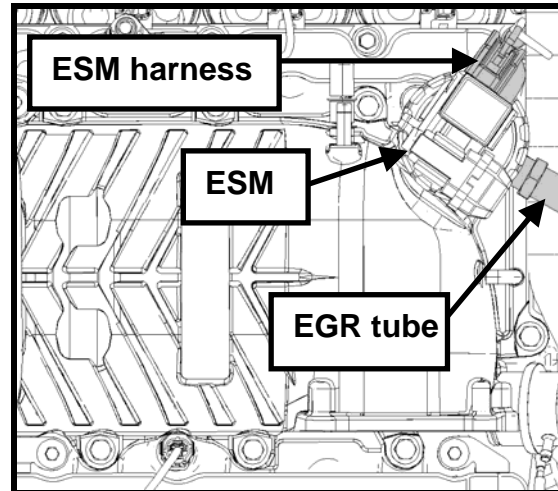

Fig. 23

Techline (800) FORD788

Factory Ford shop manuals are available from Helm Publications, 1-800-782-4356



M-6066-SGT (Black)/M-6066-SGTP (Polished) SVT Mustang Supercharger Upgrade Kit INSTALLATION INSTRUCTIONS

NO PART OF THIS DOCUMENT MAY BE REPRODUCED WITHOUT PRIOR AGREEMENT AND WRITTEN PERMISSION OF FORD RACING PERFORMANCE PARTS.

STEP 8: Re-install the vacuum harness to the ESM, supercharger and supercharger bypass actuator (See Fig. 24). **NOTE:** Ensure the harness is properly routed and all connections are fully seated.

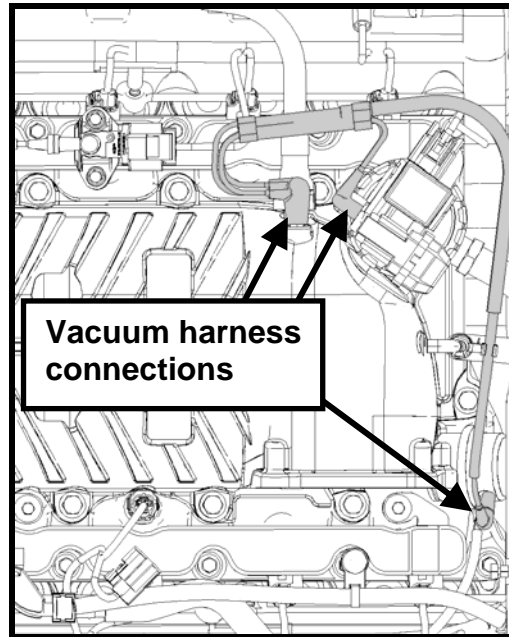

Fig. 24

STEP 9: Re-install the stock throttle body spacer assembly to the supercharger using the stock bolts and torque to 10 Nm (88 lb in) (See Fig. 25).

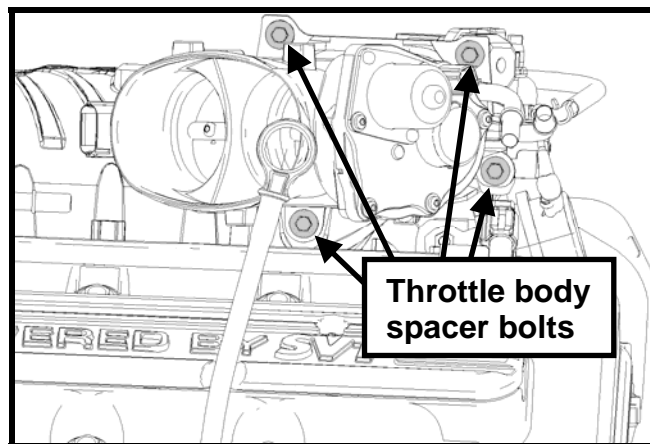

Fig. 25

Techline (800) FORD788

Factory Ford shop manuals are available from Helm Publications, 1-800-782-4356

NO PART OF THIS DOCUMENT MAY BE REPRODUCED WITHOUT PRIOR AGREEMENT AND WRITTEN PERMISSION OF FORD RACING PERFORMANCE PARTS.

STEP 10: Re-install the brake booster hose and VMV to the throttle spacer. Re-connect the electrical harness to the ETC and TPS mounted on the throttle body (See Fig. 26).

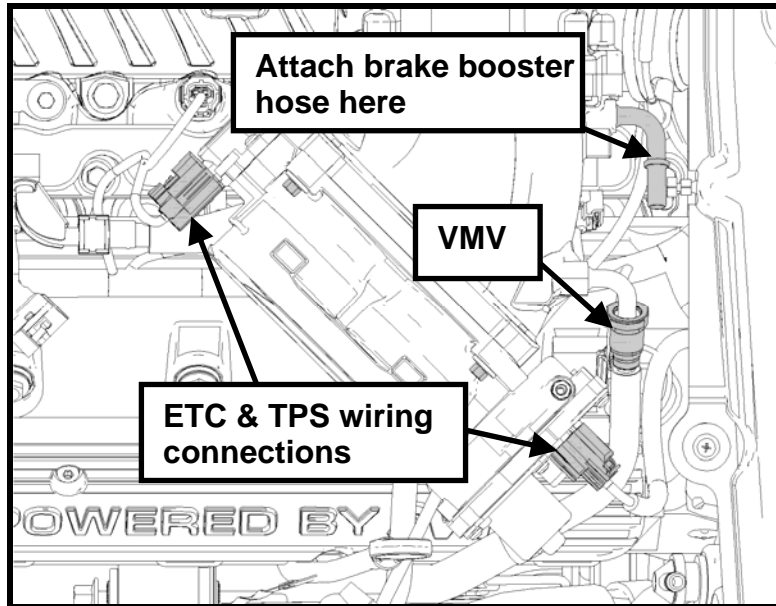

Fig. 26

STEP 11: Re-install the stock clean air tube onto the throttle body (See Fig. 27). Do not tighten the clamp at this point.

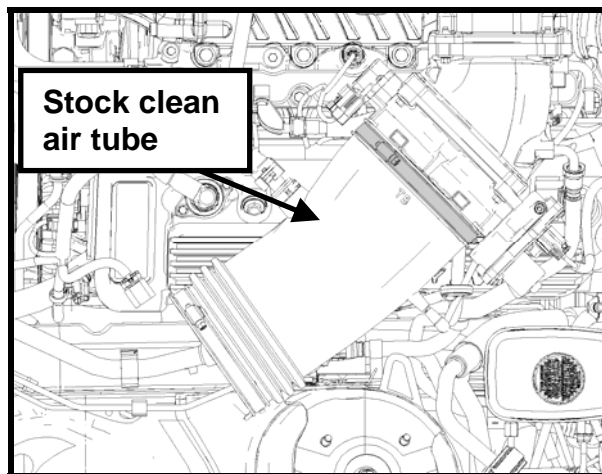

Fig. 27

Techline (800) FORD788

Factory Ford shop manuals are available from Helm Publications, 1-800-782-4356

NO PART OF THIS DOCUMENT MAY BE REPRODUCED WITHOUT PRIOR AGREEMENT AND WRITTEN PERMISSION OF FORD RACING PERFORMANCE PARTS.

STEP 12: Install the MAF sensor and bolts from the stock airbox into the new clean air tube (R07060101) (See Fig. 28). Torque the bolts to 4 Nm (35 lb in)

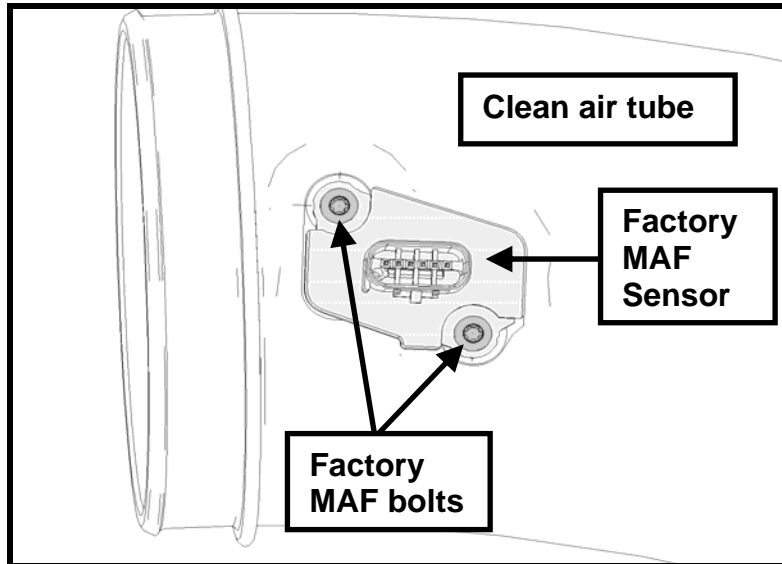

Fig. 28

STEP 13: Install the clean air tube support bracket (R07060104) to the clean air tube and position using the alignment marks on both the bracket and the tube. Secure the bracket to the tube using the bolt (N605771) supplied in the kit (See Fig. 29). **NOTE:** Apply medium-strength thread locking compound to the bolt threads prior to installation and torque this bolt to 10 Nm (88 lb in)

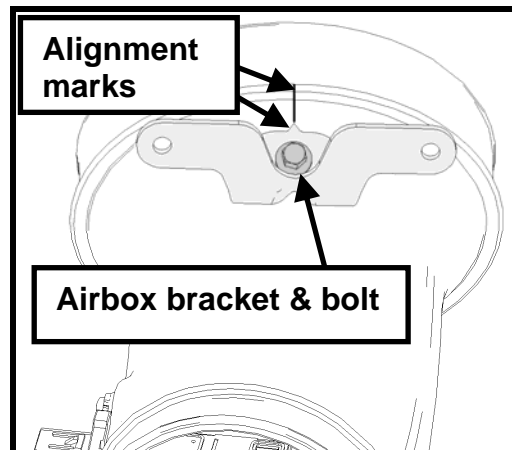

Fig. 29

Techline (800) FORD788

Factory Ford shop manuals are available from Helm Publications, 1-800-782-4356

NO PART OF THIS DOCUMENT MAY BE REPRODUCED WITHOUT PRIOR AGREEMENT AND WRITTEN PERMISSION OF FORD RACING PERFORMANCE PARTS.

- STEP 14:** Install the air filter (R07060131) to the clean air tube and torque the worm drive clamp to 3 Nm (26 lb in)
NOTE: Align the metal strip on the air filter with the alignment mark on the clean air tube (See Fig. 30).

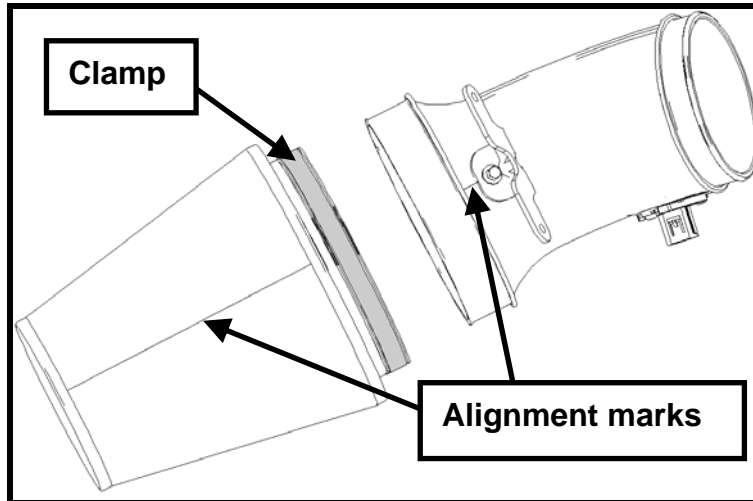

Fig. 30

- STEP 15:** Install the rubber grommet from the factory airbox into the new airbox housing (R07060106).
NOTE: Remove the metal sleeve to ease grommet insertion into the airbox. Once the rubber grommet is firmly seated in position, re-install the metal sleeve into the grommet (See Fig. 31).

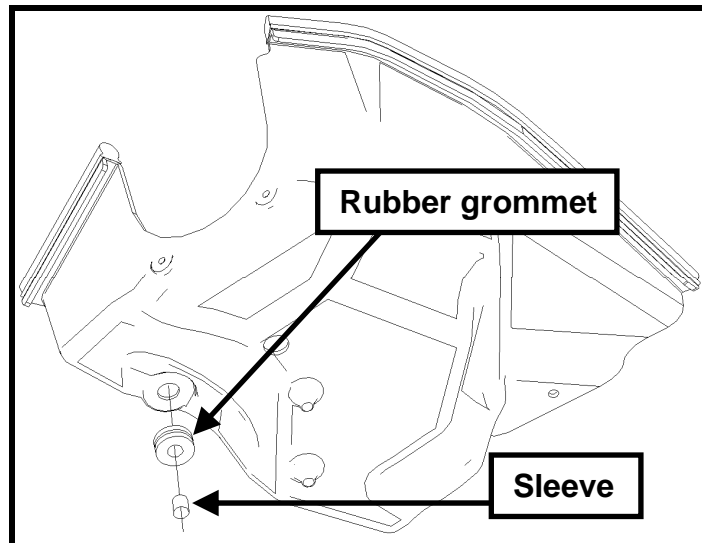

Fig. 31

Techline (800) FORD788

Factory Ford shop manuals are available from Helm Publications, 1-800-782-4356

NO PART OF THIS DOCUMENT MAY BE REPRODUCED WITHOUT PRIOR AGREEMENT AND WRITTEN PERMISSION OF FORD RACING PERFORMANCE PARTS.

STEP 16: Assemble the air tube and filter onto the airbox housing using two bolts (N605771) and torque to 10 Nm (88 lb in) (See Fig. 32).

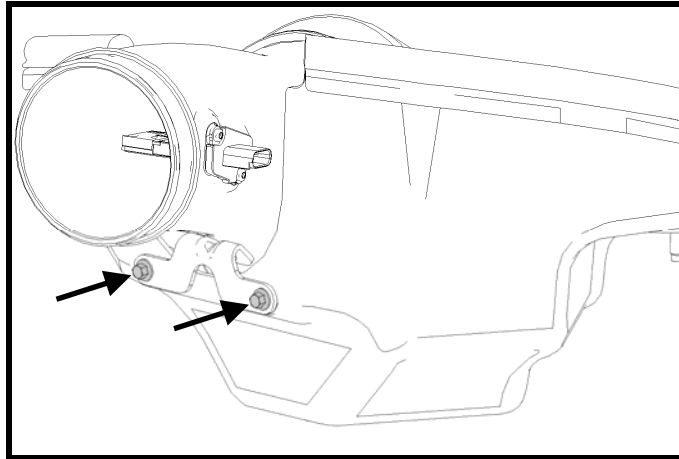

Fig. 32

STEP 17: Locate the ABS module bracket and remove the bolt shown below (See Fig. 33).

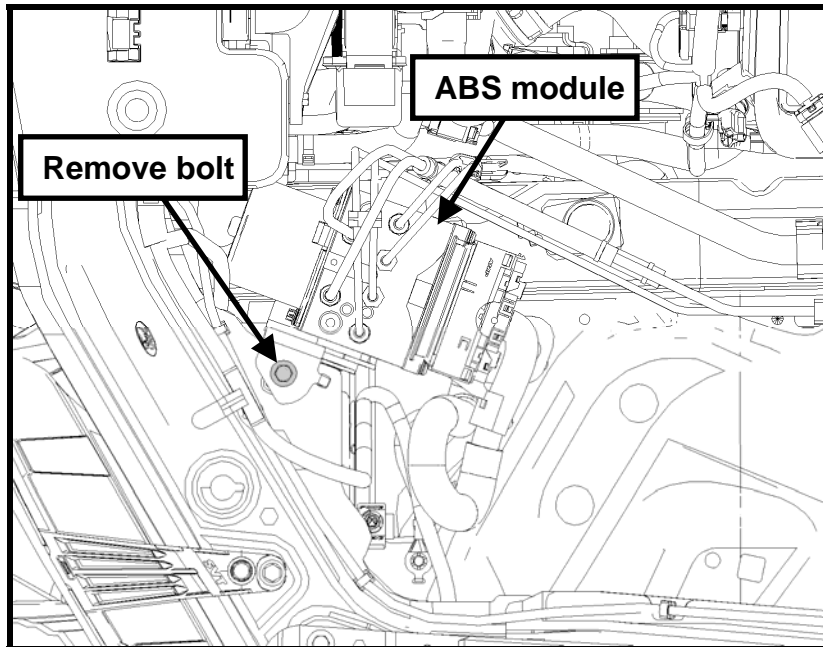

Fig. 33

Techline (800) FORD788

Factory Ford shop manuals are available from Helm Publications, 1-800-782-4356

NO PART OF THIS DOCUMENT MAY BE REPRODUCED WITHOUT PRIOR AGREEMENT AND WRITTEN PERMISSION OF FORD RACING PERFORMANCE PARTS.

STEP 18: Install the rubber grommets (previously removed from the factory airbox) into the holes located beneath the airbox, rearward of the ABS module (See Fig. 34).

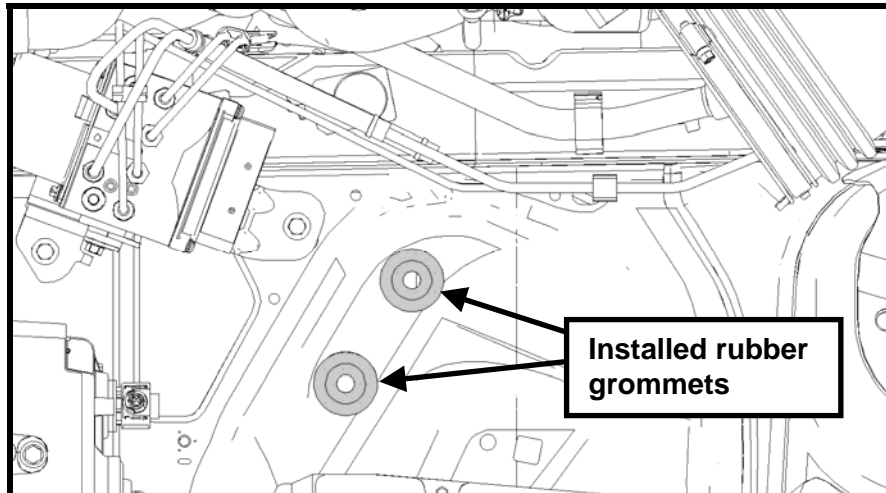

Fig. 34

STEP 19: Lower the complete airbox assembly into the vehicle using the two pegs as guides into the rubber grommets. Use the take-off airbox bolt and newly supplied ABS bracket bolt (N808920) to secure the airbox in the vehicle. Torque the M6 bolt to 10 Nm, (88 lb in) and the M8 bolt to 25 Nm (221 lb in) (See Fig. 35).

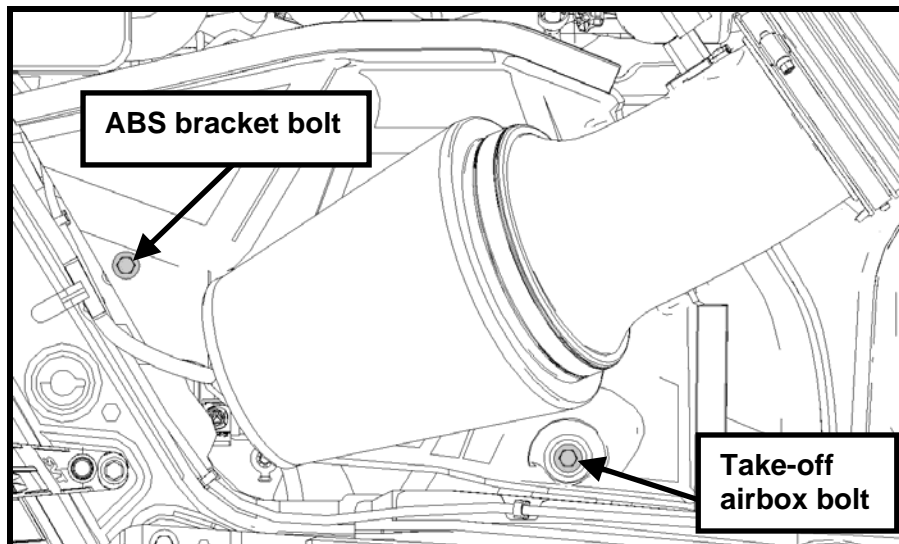

Fig. 35

Techline (800) FORD788

Factory Ford shop manuals are available from Helm Publications, 1-800-782-4356

NO PART OF THIS DOCUMENT MAY BE REPRODUCED WITHOUT PRIOR AGREEMENT AND WRITTEN PERMISSION OF FORD RACING PERFORMANCE PARTS.

STEP 20: Install the stock rubber clean air tube onto the new clean air tube/airbox assembly. Tighten both ends using worm drive clamps and torque to 3 Nm (26 lb in) (See Fig. 36).

STEP 21: Re-install the PCV line and vacuum harness onto the clean air tube. Re-install the MAF electrical connector onto the MAF sensor (See Fig. 36).

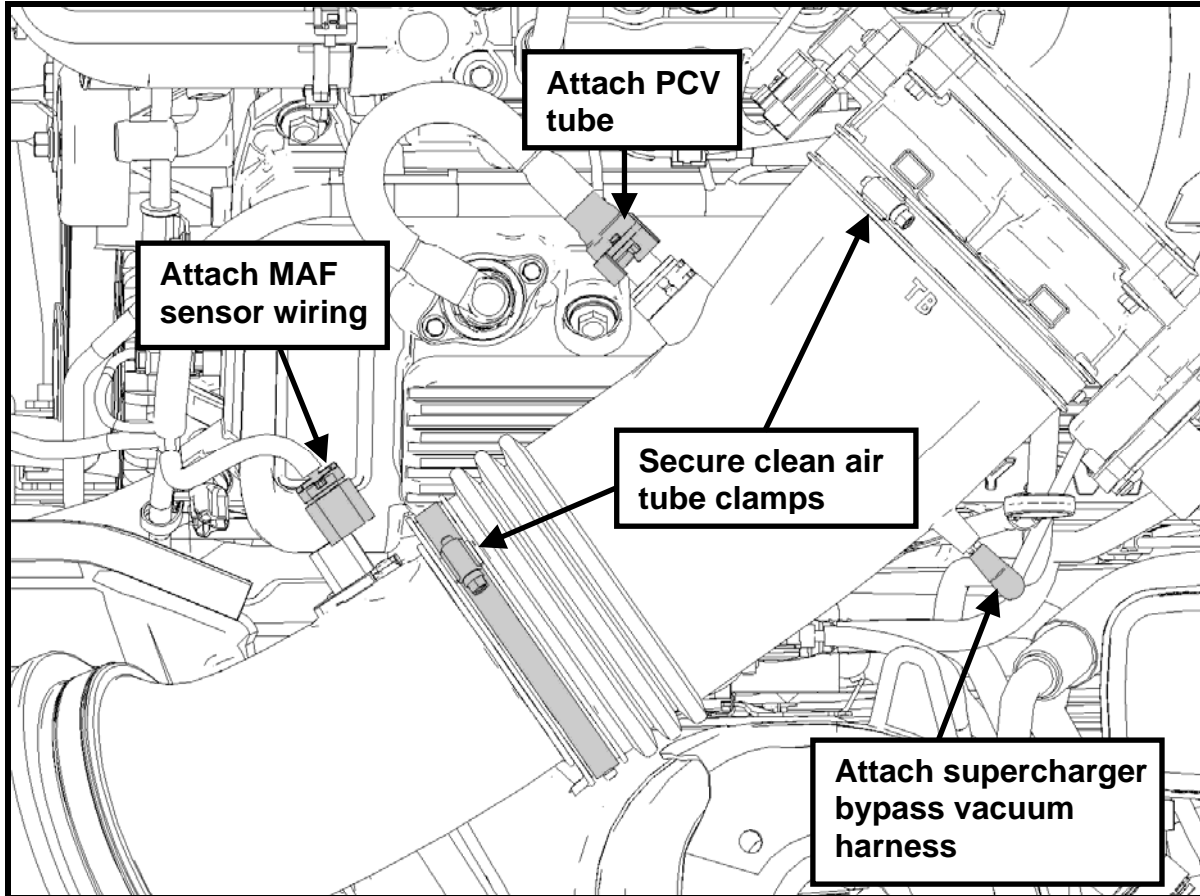

Fig. 36

STEP 22: Re-install the strut tower brace and torque nuts to 35 Nm (309 lb in)

STEP 23: Re-install the battery connections. Connect the positive (+) cable to the battery first, then the negative (-) cable. Check to insure that the battery is fully charged (12.0V to 14.5V).

Techline (800) FORD788

Factory Ford shop manuals are available from Helm Publications, 1-800-782-4356



M-6066-SGT (Black)/M-6066-SGTP (Polished) SVT Mustang Supercharger Upgrade Kit INSTALLATION INSTRUCTIONS

NO PART OF THIS DOCUMENT MAY BE REPRODUCED WITHOUT PRIOR AGREEMENT AND WRITTEN PERMISSION OF FORD RACING PERFORMANCE PARTS.

STEP 24: **VERY IMPORTANT!!! THE FOLLOWING STEPS CAN ONLY BE COMPLETED ONCE YOU RECEIVE YOUR FORD RACING PROCAL FLASH TOOL. PLEASE READ THE FOLLOWING INSTRUCTIONS CAREFULLY PRIOR TO INSTALLATION!!!**

ProCal 1 Calibration Flash Tool Instructions:

Please follow the directions below in order to make sure that your vehicle's powertrain control module (PCM) is successfully programmed (flashed) with the correct engine and transmission calibration. **Do not drive the vehicle until the programming operation has completed successfully.** Please read these instructions in their entirety prior to beginning the flash procedure. If you have any questions or concerns, please call the Ford Racing Techline at 1-800-FORD788 if they are not addressed in this document.

This ProCal tool has been designed to deliver a performance calibration to your vehicle and keep a copy of your vehicle's stock calibration should you decide to remove the performance pack for any reason. The tool will be locked to your vehicle until the stock calibration has been restored. Once the original calibration has been restored to your vehicle, the performance calibration and corresponding hardware can be installed on another vehicle of the same year, make, model, PCM part number, tire size and axle ratio.

RECALIBRATION PROCEDURE:

Before you begin:

- STEP 1:** Check to see that the battery is fully charged (at least 12.0 volts) and all accessories (radio, interior fan, headlights, etc.) are switched off. It is **strongly recommended** that the vehicle be connected to a battery charger during the flashing process to avoid potential low-voltage issues.
- STEP 2:** Locate the on-board diagnostic (OBD-II) diagnostic link connector (DLC) located beneath the dashboard on the driver's side of the vehicle. The exact location will vary with the model and year of the vehicle but will always be on the driver's side.

Flashing your PCM:

- STEP 1:** Ensure the ignition key is in the OFF position.
- STEP 2:** Hold the ProCal tool so that the side with the instructions on it is facing up and the LEDs and switch are facing you. Slide the function switch to the LEFT (toward center of unit) to select the performance calibration, or to the RIGHT (toward edge of unit) to select the stock calibration.
- STEP 3:** Connect tool to vehicle diagnostic connector and wait another five seconds. A blinking yellow light should appear which means the tool is ready to begin flashing the vehicle's PCM.
- STEP 4:** Turn key to ON position but do not start the engine. The yellow light should stop blinking and stay on during the PCM flashing process, which can take anywhere between five minutes and 40 minutes depending on the type of PCM. Please be patient and do not touch the key or turn on any accessories (such as the radio) while flashing is in process.

Techline (800) FORD788

Factory Ford shop manuals are available from Helm Publications, 1-800-782-4356

IS-1850-0146



**M-6066-SGT (Black)/M-6066-SGTP (Polished)
SVT Mustang Supercharger Upgrade Kit
INSTALLATION INSTRUCTIONS**

NO PART OF THIS DOCUMENT MAY BE REPRODUCED WITHOUT PRIOR AGREEMENT AND WRITTEN PERMISSION OF FORD RACING PERFORMANCE PARTS.

STEP 5: When the tool is finished flashing the PCM, the solid yellow light will turn off and either a solid green or solid red with blinking yellow will result. If the green light is on, turn the ignition key to the OFF position, remove the tool from the DLC and continue to STEP 6. If the red light is on, an error has occurred and the PCM has not successfully been flashed. Refer to the "Light Status" section below for diagnosis.

STEP 6: If you flashed the performance calibration into the PCM, attach the enclosed E.O. Label (R07040053) in a clearly visible location under the hood in close proximity to the newly installed performance equipment.

STEP 7: Congratulations! You have now successfully flashed the PCM. Start the engine and enjoy.

Light Status:

Solid GREEN only	Flashing process successfully completed.
Flashing YELLOW only	Ready to begin flashing process and waiting for key to be turned to ON position.
Solid YELLOW only	Flashing in process. Please be patient.
Solid RED, blinking YELLOW	Error encountered. Count yellow blink sequence and refer to the following table for error code. If the error code is not shown below, call the Techline at 1(800) FORD788 for further instructions.

Error Code Diagnosis:

<u># of yellow blinks</u>	<u>Error Description</u>
1	Vehicle mismatch. Attempting to program second vehicle before first vehicle has been returned to the stock calibration.
2	Switch position error. Try again with the switch in the other position.
3	General software upload error. Call Techline at 1(800) FORD788.
4	General software download error. Try again with battery charger connected.
6	Voltage read error. Try again with battery charger connected.
7	The battery voltage is too low. Try again with battery charger connected.
8	The battery voltage is too high. Check that correct battery is installed in vehicle.
9	The ProCal reprogramming voltage is not working properly. Check the vehicle DLC wiring.

STEP 25: After PCM has been successfully programmed (flashed), inspect all underhood wiring harnesses for potential interference issues. Use zip ties to safely position the harness away from any areas of concern.

STEP 26: Pressurize the fuel system.
NOTE: This procedure was taken directly from the Ford Service Manual, section 310-00.
a. Install the fuel pump module fuse. Its location can be seen on page 6 of this manual.

Techline (800) FORD788

Factory Ford shop manuals are available from Helm Publications, 1-800-782-4356



M-6066-SGT (Black)/M-6066-SGTP (Polished) SVT Mustang Supercharger Upgrade Kit INSTALLATION INSTRUCTIONS

NO PART OF THIS DOCUMENT MAY BE REPRODUCED WITHOUT PRIOR AGREEMENT AND WRITTEN PERMISSION OF FORD RACING PERFORMANCE PARTS.

- b. **NOTE:** It may take more than one key cycle to pressurize the fuel system. Cycle the ignition key and wait three seconds to pressurize the fuel system. Check for leaks before starting the engine.
- c. Start the vehicle and check the fuel system for leaks.

STEP 27: Check for unusual noises, dash service lights and unusual operation. If problems are detected, immediately stop the engine or vehicle and diagnose and repair the problem.

STEP 28: Affix the E.O. Label (R07040053) on driver side strut tower adjacent to the air filter assembly.

WARNING: 2007 SVT Mustangs must use upgraded damper M-6312-SVT to maintain warranty coverage

FORD RACING LIMITED WARRANTY

A Limited Warranty is valid only when proof of purchase is registered by the installing Ford dealer by contacting the Ford Racing Call Center at 1(800) 367-3788. For warranty details, please visit the www.fordracingparts.com website.

Techline (800) FORD788

Factory Ford shop manuals are available from Helm Publications, 1-800-782-4356